

S-Series (AGM) VRLA Batteries

30 – 225Ah (6 & 12 Volt Blocks)



Optional insulated cables available

Applications

- Utility (switchgear)
- Telecom
- UPS systems
- Emergency lighting
- Alarm systems

The sealed construction of the SBS S-series battery allows trouble-free, safe operation in any position. There is no need to add water to the batteries since the gases generated during charging are recombined in a unique “Oxygen Cycle”. Because of this recombination effect the batteries require no maintenance other than routine testing.

When ordered with a VR-series VRLA battery rack the S-series batteries and rack come complete with all required cables to install this economical and compact system.

Features

- Maintenance-free operation
- Low self discharge (long shelf life)
- Spill-proof construction
- Wide operating temperature
- 100% memory-free
- Non-restricted for air transportation
- UL recognized # MH19767
- Design life of 10 or more years in float service

Construction

Plates	Lead-tin-calcium alloy
Separator	Microporous glass fiber (AGM)
Case Material	ABS
Float Voltage	2.25 V/cell
Equalize Voltage	2.35 V/cell
Temp. Range	5° F to 130° F (68–77° F recommended)

AGM Advantages

- Competitively priced
- Superior high rate discharge performance
- Commonly used in stand-by applications

Technical Data

Part No.*	8 Hr Ah Rate	20 Hr Ah Rate	Voltage (V)	Battery Dimensions L x W x H (in.)	Weight (lbs.)	I.R. (mOhms)
S-12330	32	33	12	7.68 x 5.12 x 7.01	24.7	11.0
S-12400	36	40	12	7.76 x 6.50 x 6.69	26.9	10.0
S-12550	52	55	12	9.02 x 5.43 x 8.90	36.3	7.5
S-12750	72	75	12	10.20 x 6.61 x 8.43	49.2	6.6
S-12900	85	90	12	12.99 x 6.81 x 8.35	61.7	5.0
S-12V120	100	120	12	12.99 x 6.81 x 8.66	67.0	4.1
S-6V195	190	210	6	12.10 x 6.61 x 8.98	62.2	1.2
S-6V220	200	220	6	12.68 x 7.01 x 9.21	67.3	1.4
S-6V225GC	200	220	6	10.30 x 7.09 x 9.96	67.3	3.2

*Additional models available. Please contact SBS for more information.

VRLA Battery Rack Configurations

For 6 & 12 Volt S & G-series batteries between 30 and 225Ah

The SBS VRLA racks have adjustable rails allowing them to hold top terminal 6 or 12 volt VRLA batteries ranging from 30 to 225Ah (100 to 800Wpc). The heavy duty yet light frame makes them easy to move and install.

Features

- When ordered with batteries includes cables and jumper(s)
- -Z4 racks seismically certified to Zone 4 UBC standards
- Powder coated with ASA 61 Gray corrosion resistant, epoxy powder
- All welded construction with 7 GA frame and rails
- Floor mounting brackets included with all racks
- Ship preassembled for fast installation
- Adjustable rails with 3" lip

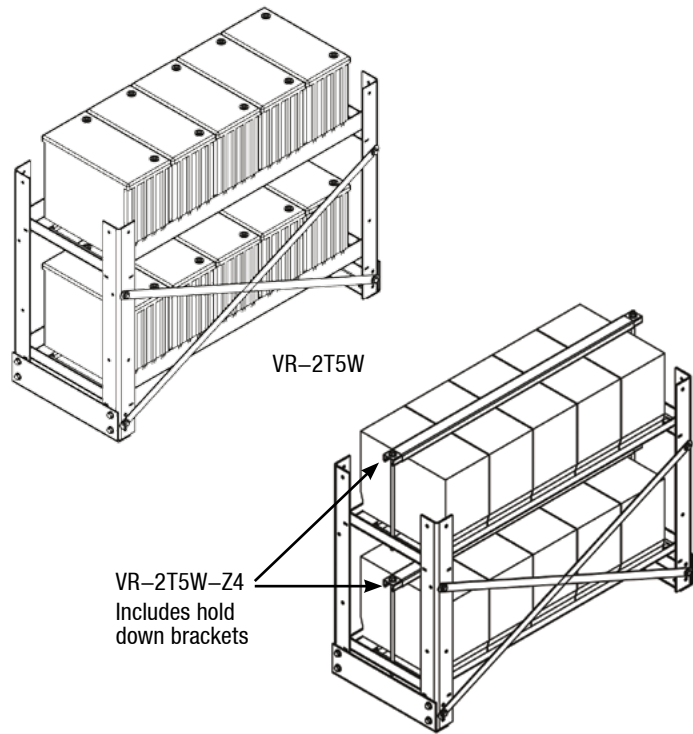

Seismic Zone 4 Certified

The VRLA rack rails have 3" high lips. Batteries that are shorter than 7" high do not require the '-Z4' hold down bracket option for seismic Zone 4 applications.

When a seismic rack is required for VRLA batteries taller than 7" high the '-Z4' option should be ordered and a hold down bracket kit will be provided with the rack.

Technical Data

Part No.	Description	Batteries (6 or 12V)	Dimensions W x D x H (in.)	Weight (lbs.)
VR-1T4W	1 tier x 4 batt.	4	31.5 x 16.3 x 28.3	30
VR-1T4W-Z4	1 tier x 4 batt.	4	31.5 x 16.3 x 28.3	36
VR-2T4W	2 tier x 4 batt.	8	31.5 x 16.3 x 28.3	40
VR-2T4W-Z4	2 tier x 4 batt.	8	31.5 x 16.3 x 28.3	46
VR-2T5W	2 tier x 5 batt.	10	40.5 x 16.3 x 28.3	50
VR-2T5W-Z4	2 tier x 5 batt.	10	40.5 x 16.3 x 28.3	56
VR-4T5W	4 tier x 5 batt.	20	40.5 x 16.3 x 67.5	98
VR-4T5W-Z4	4 tier x 5 batt.	20	40.5 x 16.3 x 67.5	104

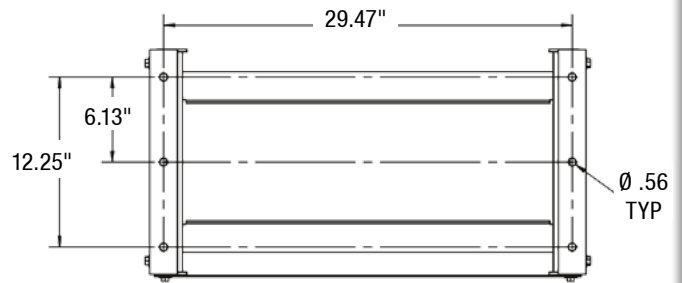

Bottom view – mounting footprint for 31.5"W racks

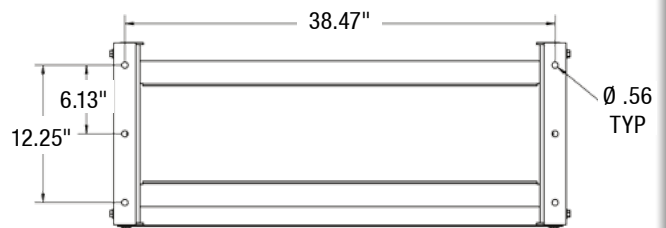

Bottom view – mounting footprint for 40.5"W racks